

Instruction Manual for UPPPU

Contents.....

1. Product Overview
2. Operations
3. Installation & Commissioning Instructions
4. Bill of Material
5. Maintenance and Troubleshooting
6. Storage

1.Product Overview:-

UKL Condensate Pumping Package is designed for transfer of condensate from the area of steam utilization to the boiler feed circuit.

This condensate can then be used as an ideal source for boiler feed water. The UPPPU is an essentially mechanical pump, which derives motive force from the pressure of a motive gas usually steam or compressed air. The main advantages of using mechanical pumps are lower operating cost, less maintenance, higher reliability and no pump cavitations due to high temperature etc.

The other advantage being the possible use in hazardous area where use of electrical power is prohibited.

UPPPU is supplied as a complete skid mounted unit, inclusive of the condensate receiver, inlet piping with required head, the main pumping unit, accessories for controlling the operation of the pump and a simple mechanical flow totalizer as an option for measuring the quantity of condensate.

2.OPERATIONS :-

The UKL Pressure Pump Unit operates on a positive displacement principle.

The condensate from a receiver tank, flows by gravity into main pump body. As the condensate level in the pump body rises the float attached to central fork also rises up. At a predetermined float position, a spring aided mechanism snaps open the motive pressure inlet valve so that motive fluid flows in the pump. This motive fluid drive the condensate towards outlet. When the condensate is pumped the level inside the pump body falls causing float to descend towards lower position. At this point the spring mechanism again snaps back to open exhaust valve and close the motive fluid inlet valve. The exhaust valve open to drive the expanded motive fluid by incoming condensate, to be driven out of pump.

It is important to note that the steam is not used to pump water. The pressure exerted by steam is used as a motive force. Hence steam consumption is very little.



3. Installation and Commissioning Instructions:

UKL make Condensate Pumping Package will provide you with long, trouble-free service if they are correctly installed and maintained.

A few minutes of your time spend reading these instructions now may save hours of trouble and downtime later.

- Before installing UPPPU, the inlet piping should be carefully blown down to remove any existing pipe debris.
- Level the floor where UPPPU is going to be installed. Do not install the Pump in underground pit. It is not recommended as the cleaning and maintenance operations become far more difficult. Condensate coming to the receiver has sufficient pressure head to enter receiver at a slightly static head.
- Connect the condensate discharge lines to the receiver unit through the flanges provided on top of the receiver in such a way that condensate should fall by gravity into the receiver tank. In case there are more number of condensate lines, fabricate a separate header to collect condensate before the receiver. As the receiver is designed for atmospheric pressure operation, the condensate should be at a low pressure.

In case condensate is available at high pressure, consider the use of UKL flash vessel to reduce the condensate pressure. In this process low pressure flash steam will be available for use in the process from the high pressure condensate.

- Please ensure that the receiver has one connection left open as vent to atmosphere.
- The receiver has been provided with an overflow connection which should not be connected to a pressurized source. The overflow is meant to allow excessive condensate , coming momentarily at a rate higher than the pumping capacity of the pump to be out.
- Motive steam or compressed air source should be connected to the inlet valve motive fluid piping of the condensate pump. This has been provided with a TD trap for draining condensate from motive steam. The motive fluid pressure should not exceed 8 Kg/cm²(g).
- Make sure that the motive fluid line is properly drained at the time of starting the pump.
- Clean all inlet, outlet piping from the receiver. Ensure that the receiver itself is cleaned properly.
- Plug all the open nozzles securely for tight shut off. Keep the vent nozzle on the receiver open to atmosphere.
- Ensure that the inlet and outlet pipeline, isolating valve strainer and both check valves provided on the pump unit are cleaned and fitted properly before starting the pump.
- Now connect the outlet of the pump to condensate return line going to the feed tank.
- Connect motive fluid line to the inlet on top of pump unit. It is recommended to install a pressure gauge on the motive line..
- For best performance it is recommended that the entire lift should come immediately after the pump. Connect the condensate return line to the feed water tank in such manner that the bends/elbows used are minimum. It is essential to ensure that the condensate return line is not submerged in water while connecting to the BFW tank. If the line is submerged in water, the pumping stroke will lead to water hammer and excessive vibrations.

4.BILL OF MATERIAL:-

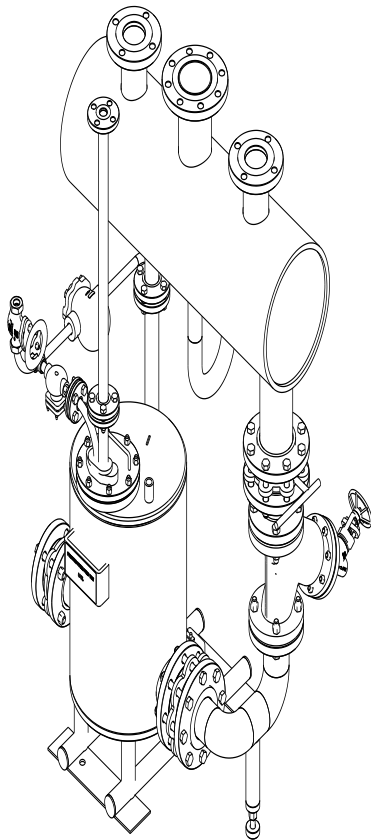
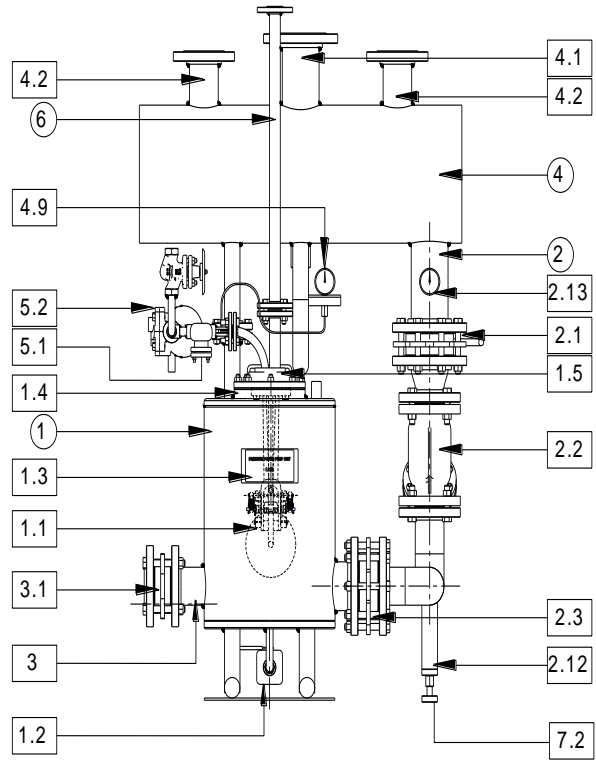
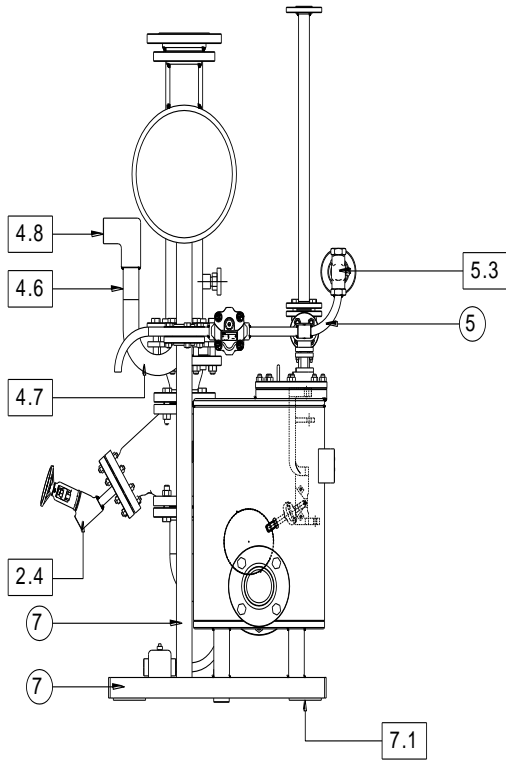

Part No.	Description	Size	Material Grade	MOC
Pump Tank Assembly				
1	Pipe	16" NB	Carbon Steel	ASTM A106 Gr. B
1.1	Internal Assembly	---	---	---
1.2	Ball Valve (Local)	1/2"	Carbon Steel	ASTM A216 Gr. WCB
1.3	Name Plate	---	Stainless Steel	AISI 304
1.4	Cover Ring	---	Carbon Steel	IS 2062 B
1.5	Cover	---	Carbon Steel	ASTM A216 Gr. WCB
Inlet Pipe Assembly				
2	Pipe	4" NB	Carbon Steel	ASTM A106 Gr. B
2.1	Sandwich Type Butter fly Valve	4"	Carbon Steel	ASTM A216 Gr. WCB
2.2	Strainer 'Y' - 40 Mesh	3"	Carbon Steel	ASTM A216 Gr. WCB
2.3	Disc Check Valve	4"	Carbon Steel	ASTM A351 Gr. CF8M
2.4	USN - 15 SW (2 Bolt)	1/2"	Carbon Steel	ASTM A105
2.12	Adjustable Support	---	Carbon Steel	---
2.13	Temperature Gauge	---	Stainless Steel	AISI 304
Outlet Pipe Assembly				
3	Pipe	3" NB	Carbon Steel	ASTM A106 Gr. B
3.1	Disc Check Valve	3"	Stainless Steel	ASTM A351 Gr. CF8M
Receiver Tank				
4	Pipe	12" NB	Carbon Steel	ASTM A106 Gr. B
4.1	Vent Nozzle - Pipe	4" NB	Carbon Steel	ASTM A106 Gr. B
4.2	Inlet Nozzle - Pipe	3" NB	Carbon Steel	ASTM A106 Gr. B
4.6	Over Flow Pipe	1-1/2"	Carbon Steel	ASTM A106 Gr. B
4.7	Bend -180°	1-1/2"	Carbon Steel	ASTM A105
4.8	Threaded Elbow	1-1/2"	Carbon Steel	ASTM A105
4.9	Pressure Gauge(0-21)	---	Stainless Steel	AISI 304
Motive Pressure Line				
5	Pipe	1/2"	Carbon Steel	ASTM A106 Gr. B
5.1	USRM - 40 Mesh	1/2"	Carbon Steel	ASTM A105
5.2	UFTN - 4.5 D.P.	1/2"	Carbon Steel	ASTM A216 Gr. WCB
5.3	USN - 15 SW (2 Bolt)	1/2"	Carbon Steel	ASTM A105
Exhaust Line				
6	Pipe	1"	Carbon Steel	ASTM A106 Gr. B
Support Fabrication				
7	Pipe	1-1/2"	Carbon Steel	ASTM A106 Gr. B
7.1	Foundation Plates	---	Carbon Steel	---
7.2	Adjustable Screw	---	Carbon Steel	---

5. Maintenance and Troubleshooting:

- **Strainers**

The condensate inlet line as well as the steam inlet line has been provided with strainer to prevent welding slag, dirt and other particles from the damaging the critical components of the unit. These strainers have a mesh in them, which needs to be cleaned periodically to prevent choking. We recommend that this is done quarterly. Before removing any of the components of the system ensure that all connections to the unit i.e. steam and condensate are isolated to prevent injury to personnel or damage to the unit.

- **Other Parts**

The internals of the unit are factory assembled and tested and should not be tampered with as far as possible. We recommend that the unit is serviced annually, with the help of our Trained service personnel. It is also recommended that the operating and maintenance staff are duly trained at our Training center.

However in extreme conditions of dirt or particles getting into the main pump unit, the components like strainers and check valves may get choked. It is also possible that the inlet and exhaust valves on motive fluid service may get stuck, ceasing the operation of the pump. In such a case remove the top flange of the main pump unit, noting the orientation of all lines check that the float assembly is free and movement of float controls the inlet and exhaust operation. Check the operation with pneumatic signal while the float assembly is outside. Refit the top flange replacing any gaskets if required.

The check valves on the inlet and outlet of the pump are spring loaded wafer type check valves. The disc in these valves sits on a metal seat, and any particles getting lodged on the seat can cause a leak in the valve in the reverse direction. The check valves can be removed by opening three of the four flange bolts and swinging the valve out. It may then be inspected and cleaned. While replacing the valve check the condition of the gaskets and ensure that the valve is properly positioned.

- **Float Assembly:**

1. Remove the internal assembly from the tank with cover plate.
2. Unscrew the M12 hex bolts (2 Nos) and separate the frame assembly from the cover the outlet valve spool will come out of the disc fitted to the connecting rod.
3. Before fitting the new frame assembly insert the outlet valve and insert the disc in the outlet valve spool slot.
4. Fit the frame to cover by M12 hex bolts.
5. After fitting the frame assembly checks for outlet and inlet valve operation as follows:
When outlet valve is closed inlet valve should be lifted up by the disc.(Open Condition)
Check by applying air to outlet and inlet connections.
When outlet valve is open their must be gap between disc and inlet valve spool(Closed Condition). Check again by applying air to outlet and inlet connections.
6. If both the above conditions satisfy assembly can be fitted in the tank.

TROUBLESHOOTING:

- **No Stroke by the Pump:**

The most likely reason for this is improper flow of the condensate by gravity from the receiver to the pump. Check and Clean the pipeline and the accessories including the check valves. Ensure that the condensate is coming to the pump receiver. If the problem persists, contact UKL.

- **Pump Does not work on START UP**

The pump may not be filling, check that condensate inlet valve is open (the handle will be in line with the piping in open position) If the valve is open, the strainer may be choked. Clean and replace the mesh if required.

If the pump is filling, it may not pump the condensate if the motive line is closed or if the pressure is not sufficient. Check the strainer provided on the trap. It should be clean.

Check that the steam inlet valve is open, and that the pressure is at least 0.5 to 1 bar higher than the static head against which the pump is discharging.

Check the operation of DCVs (Check valves) provided at inlet and outlet of the pump. If required clean the check valves. Ensure that the motive steam line is cleaned.

- **Pump appears normal, but condensate overflows**

The condensate is collected in the receiver before flowing into the pump by gravity. If the receiver overflows, it means that the condensate is not being pumped as fast as it is accumulating in the receiver.

This may happen if the pump is not sized properly and the flow capacity of the pump is less than the quantity of condensate coming to the receiver.

This may happen if for a short time the incoming condensate flow rate is more than the pumping rate. Check the capacity table to see if the capacity is sufficient.

The pump may not be filling quickly if there is any choking or restriction in the condensate inlet line. Check the inlet valve position and the strainer mesh.

The unit may also malfunction if the steam inlet valve is stuck. If so isolate the steam inlet and relieve the pressure, then inspect steam inlet valve and replace if necessary.

If the delivery line is undersized or has excessive bends and complex routing, the pumping operation may get hampered. This could also cause the receiver to overflow inspite of pump making normal strokes.

6 Storage:

- UPPPU and the respective spares should be stored only in enclosed dry rooms in a non-aggressive atmosphere. Fully assembled UPPPU must be stored as supplied by UNI KLINGER. Spare parts must be handled with care and should be stored in their original packing.
- It is recommended to take protective measures if parts are stored in dusty conditions.
- The ambient temperature in store room must be between -4 Deg. F and +122 Deg. F.
- Sudden change in temperatures must be avoided.
- Any damage due to inappropriate storage shall release UNI KLINGER of any obligations derived from warranty, guarantee, and product liability.



Other Products : Cast / Forged Steel Piston Valves, Bellow seal valves, High Pressure valves (Gate/Globe) , Strainers – “Y” Type, ITVS
Steam Traps (Thermodynamic, Thermostatic, Ball Float Traps and IBT), Pressure Reducing Station, Condensate Recovery Products.
Level Gauges (Reflex, Transparent, Bicolor), Sight Glass, Hot Water Generation System, Safety and Relief Valves.
FSD Products : Compressed Asbestos / Non Asbestos Fiber Sheeting / Cut Gaskets, Spiral Wound Gaskets.

In view of technical progress design and dimensions are subjected to change without notice.



UNI KLINGER LIMITED

A joint venture of the Neterwala group of companies and KLINGER AG. Switzerland.

Central Sales Office & Pune Branch : SC1, 5th Fl., Kohinoor Est. Mumbai-Pune Highway, Khadki, Pune-411 003. Tel.: +91-20-4102 3000 Fax.: (020) 4102 3001
e-mail : salesco@uniklinger.com, salespune@uniklinger.com, Website : www.uniklinger.com

Factory : C-37, M.I.D.C., Ahmednagar – 414 111, Maharashtra, Tel. : 0241 – 277223 / 2777512 Fax : 0241 – 277294, E-mail : fdworks@uniklinger.com

Branch Offices :

Baroda : 102, 1st Floor, Otel Towers-II R.C. Dutt Road, Baroda-390 005, Tel.: 91-0265-2312343 / 2340660, Fax.: 91-265-2341419, E-mail : salesbar@uniklinger.com
Chennai : East Coast Centre, 5th Floor, 553, Mount road, Teyyanampet, Chennai - 600 018, Tel.: 91 - 44 - 24345707, Fax.: 91 - 44 - 24343960, E-mail : saleschen@uniklinger.com
Kolkata : 9, Chittrakoot, 8th Floor, 230 A, A.J.C Bose road, Kolkatta-700 020, Tel.: 91-33-22872510, Fax.: 91-33-22876494, E-mail : salescal@uniklinger.com
Mumbai : 22, 2nd Flr, Shreeji Arcade CHS, Almeda road, Thane-400 602, Tel.: 91-22-25421140 / 91-22-25440461, Fax.: 91-22-25440463, E-mail : salesmum@uniklinger.com
Delhi : 321, Ansal Chamber-II, 6, Bhikaji Cama Place, New Delhi-110 066, Tel.: 91-11-41658767 / 91-11-26193847, Fax.: 91-11-41658768, E-mail : salesdel@uniklinger.com