

UNI KLINGER is keeping with the innovative Methods to help Process Industries achieve higher levels of operational Efficiency have to proper and thorough mixing of Boiler Feed water with the other available thermal streams as well as removal of non condensable gases from BFW tank.

**What is a Deaerator Head –**

An attachment to the existing BFW tank

- Mixing nozzles for Flash steam, Condensate from Plant areas and Fresh Make-up water
- SS perforated mixing pipe immersed in feed water
- Optional recycling water circulation system on Request.

**Features:-**

Various reasons to go for Deaerator Head for Process Boilers

- Removes Air, Oxygen, and other non condensable gases.
- Provides effective mixing of BFW with available thermal streams.
- Immersed Perforated Pipe allows uniform heating in Feed water tank.
- Improves efficiency of Boilers by preheating Feed water.
- SS internals avoid corrosion.
- HP boilers can afford to go for a pressurized de-aeration system.

But for process boilers a separate DA vessel will cost as much as the boiler cost and may not be affordable and justified.

**MATERIAL OF CONSTRUCTION:**

Body Carbon Steel/ Stainless Steel

Internals SS 316

**SIZES AVAILABLE:-**

150 NB to 300 NB

(Other sizes also available as per application)

**INSTALLATION:-**

Preferably in Vertical position.

**OPERATING CONDITIONS :**

Maximum Operating Pressure : 10.50 kg/cm2(g)

Maximum Operating Temperature : 400°C

**OPTIONAL:-**

IBR/Non-IBR

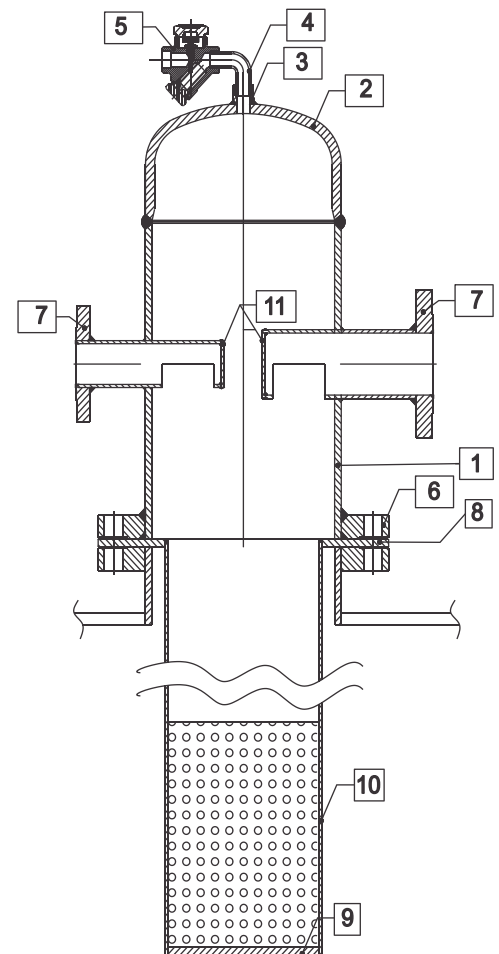

# Deaerator Head UDH

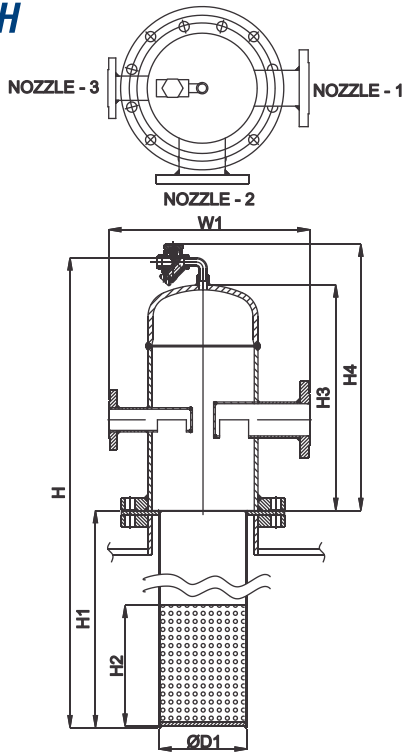

## BILL OF MATERIAL:-

11	End Plate	Carbon Steel	Carbon Steel
10	Deep Tube SCH. 10` S	Stainless Steel	AISI 316
9	End Plate	Stainless Steel	AISI 316
8	Connecting Plate	Stainless Steel	AISI 316
7	SORF Flanges Class 150	M.S.	M.S.
6	Branch Pipe	Carbon Steel	ASTM A 106 Gr. B
5	Thermostatic Trap	Forged Steel	ASTM A 105
4	Bend 1/2"	M.S.	M.S.
3	Half Coupling BSP #3000	Carbon Steel	ASTM A 105
2	Dish End	M.S.	M.S.
1	Deaerator Head Pipe SCH.40	Carbon Steel	ASTM A 106 Gr. B
<b>No.</b>	<b>PART NAME</b>	<b>MATERIAL</b>	<b>MATERIAL CODE</b>

SR.	Size	Deaerator Head ØD (Inches)	Perforation Tube ØD1 (Inches)	Height H (mm)	Height H1 (mm)	Height H2 (mm)	Height H3 (mm)	Height H4 (mm)	Width W (mm)	Width W1 (mm)	Condensate Nozzle -1	Flash Steam Nozzle -2	Make up Nozzle -3
1	150 NB	6"	4"	1760	1200	400	450	560	188	356	50 NB	80 NB	40 NB
2.1	200 NB	8"	6"	1860	1200	400	550	660	214	417	80 NB	100 NB	50 NB
2.2	200 NB	8"	6"	2460	1800	400	550	660	214	417	80 NB	100 NB	50 NB
3.1	250 NB	10"	8"	2510	1800	500	600	710	241	471	100 NB	150 NB	80 NB
3.2	250 NB	10"	8"	3110	2400	500	600	710	241	471	100 NB	150 NB	80 NB
4.1	300 NB	12"	10"	2710	1800	500	800	910	266	522	125 NB	150 NB	100 NB
4.2	300 NB	12"	10"	3310	2400	500	800	910	266	522	125 NB	150 NB	100 NB

### HOW TO ORDER

While ordering always specify total length, design and working pressure/Temperature.  
Example :- UDH 200 NB Total Length 1860 mm



Cast / Forged Steel Piston Valves, Bellow seal valves, High Pressure valves (Gate/Globe), Strainers – "Y" Type, ITVS Steam Traps (Thermodynamic, Thermostatic, Ball Float Traps and IBT), Pressure Reducing Station, Condensate Recovery Products. Level Gauges (Reflex, Transparent, Bicolor), Sight Glass, Hot Water Generation System, Safety and Relief Valves.

**FSD Products:** Compressed Asbestos / Non Asbestos Fiber Sheeting / Cut Gaskets, Spiral Wound Gaskets / Gland Packing

In view of technical progress designs and dimensions are subject to change without notice.



## UNI KLINGER LIMITED

A joint venture of the Neterwala group of companies and KLINGER AG, Switzerland.

Central Sales Office & Pune Branch : SC-1, 5th Fl., Kohinoor Est. Mumbai-Pune Highway, Khadki, Pune-411 003.

Tel.: +91-20-4102 3000 Fax.: (020) 4102 3001

e-mail : salescso@uniklinger.com, salespune@uniklinger.com, Website : www.uniklinger.com

Factory :

C-37, M.I.D.C., Ahmednagar – 414 111, Maharashtra, Tel. : 0241 – 2777223 / 2777512

Fax: 0241 – 2777294, E-mail : fcdworks@uniklinger.com

### Branch Offices :

**Baroda** : 102, Otel Towers-II 1st Floor, R.C. Dutt Rd, Baroda-390 005, Tel.: 91-0265-2312343 / 2340660, Fax.: 91-265-2341419. E-mail : salesbar@uniklinger.com

**Chennai** : East Coast Centre, 5th Floor, 553, Mount Rd, Teyanampet, Chennai - 600 018, Tel.: 91 - 44 - 24345707. Fax.: 91 - 44 - 24343960. E-mail : saleschen@uniklinger.com

**Kolkata** : 9, Chitrakoot, 8th Floor, 230 A, AJC Bose Rd, Kolkatta-700 020, Tel.: 91-33-22872510, Fax.: 91-33-22876494. E-mail : salescal@uniklinger.com

**Mumbai** : 714, Ecstasy, City of Joy Complex, J.S.D. Rd, Mulund (W) Mumbai - 400080, Tel.: 91-22-25440463, Fax.: 91-22-25440463. E-mail : salesmum@uniklinger.com

**New Delhi** : 1003, 10th Flr., Indra Prakash Bldg. 21, Barakhamba Rd, Connaught Place New Delhi-110001, Tel.: 91-11-41658767, Fax.: 91-11-41658768. E-mail : salesdel@uniklinger.com

