

Instruction Manual for Air Eliminator Trap

UAET

Contents.....

- 1. Product Overview
- 2. Installation & Commissioning Instructions
- 3. Operations
- 4. Maintenance and Troubleshooting
- 5. Storage

1.UKL COMPRESSED AIR TRAP :-

•UKL Air Eliminator trap removes the trapped air from liquid lines/process equipments. Air is a harmful ingredient in steam going to process areas. Presence of air aids corrosion and leakage from pipelines and from vessels. Air can enter steam space through Boiler Feed Water circuit. Air can enter from atmosphere when steam condenses over long stoppages.

During start up when the air from liquid lines/process equipment enters Air eliminator trap, it passes through outlet port, when the liquid enters the Air Eliminator Trap the float rises and closes the outlet port and restrict the liquid to flow out.

MATERIAL OF CONSTRUCTION:

CAST IRON MODEL

UAET-14 Model- IS 210 FG260

CAST CARBON STEEL MODEL

UAET- 20 Model- ASTM A216 Gr. WCB

OPERATING CONDITIONS:-

UAET-14 CAST IRON MODEL

Max Operating Pressure :- 13.26 Kg/cm²
Max Operating Temperature :- 220 °C

UAET-20 CAST STEEL MODEL

Max Operating Pressure :- 32 Kg/cm²
Max Operating Temperature :- 425 °C

INSTALLATION :-

Horizontal/Vertical position.



SIZES AVAILABLE:-

UAET-14 Model: 15 NB, 20 NB and 25 NB
UAET-20 Model: 15 NB, 20 NB and 25 NB

OPTIONAL:-

IBR/Non-IBR
Inbuilt Strainer
Flanged End #150/#30
Available Diff. Pressure (bar)
UAE CI Model :- 4.5/10/14
UAE CS Model :-4.5/10/14/21/32

END CONNECTIONS:

UAET-14 CAST IRON MODEL
Threaded to NPT , BSP and BSPT.

UAET-20 CAST CARBON STEEL MODEL :-
Threaded to NPT , BSP and BSPT.
Socket Weld to ASME B 16.11
Flanged End #150/#300 (On Request)

2. Installation and Commissioning Instructions:

Your UKL make Air Eliminator traps will provide you with long, trouble-free service if they are correctly installed and maintained.

A few minutes of your time spend reading these instructions now may save hours of trouble and downtime later.

- Air Eliminator trap must always be installed in horizontal position, the float assembly movement must be vertical. Hence the arrow on name plate must point downwards.
- Before installing trap, the inlet piping should be carefully blown down to remove any existing pipe debris.
- A strainer must be installed on inlet line of Air Eliminator Trap to ensure clean flow through trap.
- An arrow mark is punched on every trap body showing the flow direction. Install the trap by fixing the inlet & outlet ports accordingly. The traps are supplied with flow from left inlet to right outlet (L-R) or R-L. The 15/20/25 NB Float traps are supplied with vertical connections i.e. top inlet and bottom outlet.
- The connection orientation can be changed from L-R to R-L in horizontal connection on site itself by rotating cover to required direction.
- The SLR has to be opened at time of start up to avoid Air locking of the trap.
- It is advisable to install the Isolation Valves on either sides of trap to facilitate the servicing.
- It is preferable to install a 'Test Valve' at outlet & before isolation valve for testing the trap functioning.
- Testing of trap: trap can be tested either by Test Valve, pyrometer, ultrasonic stethoscope or a rod with sufficient length can be touched to the trap body & vibrations can be sensed by hands if trap is operating.

3. Maintenance and Troubleshooting:

MAINTENANCE:

- When the Air Eliminator trap will malfunction, it can be checked by observing the discharge of the trap. Compressed Air traps discharge continuously. If the trap is locked in close condition, check the maximum allowable differential pressure (stamped on the trap) is not exceeded.
- If the trap is leaking liquid media, close the inlet valve for a few minutes, then gradually open so that the priming of the trap will take place.
- If the trap continues to leak liquid media, remove the trap from the line, back flush it with water, and check it again for normal operation.
- If trap do not operate normally, verify that the trap is correct for the application (capacity, differential pressure, etc.). If not correct, install a new steam trap in its place.

PROCEDURE TO REPLACE UAET FLOAT ASSEMBLY:-

- Dismantle the body & cover by unscrewing M 10 hexagonal bolts (6 nos.)
- Dismantle the float from pivot bracket by removing pivot pin.
- Remove pivot bracket & support bracket by unscrewing M5 screws (2 nos.)
- Unscrew the valve seat.
- Replace the valve seat of appropriate differential pressure.
- Fix pivot bracket & support bracket on valve seat by screwing M 5 screws (2 nos.)
- Replace the new float assembly to pivot bracket by pivot pin (assure proper sitting of steel ball on to the valve seat orifice).
- Check for no air leakage through valve seat if air applied from outlet connection with valve in closed condition & float assembly resting on valve seat orifice by self-weight.
- If the above condition is satisfied assemble body with cover by installing the gasket provided, Assemble M10 bolts after fitting Dowell pin (Replace cover gasket & apply 30 to 35 N m . Torque)
- Hydro test the ball float trap at 1.5 times the operating pressure to ensure that there is no leakage.

BILL OF MATERIAL:

UAET14/UAET-20

Size- 15 NB/20 NB/25 NB

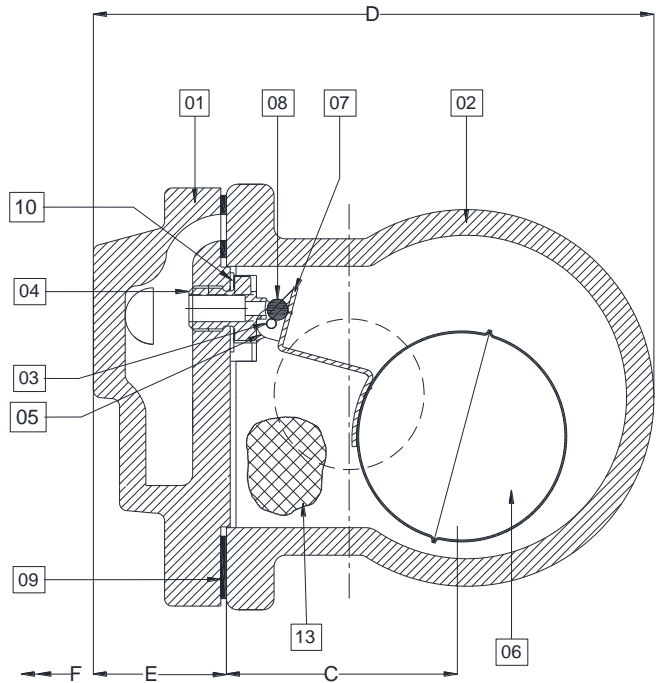
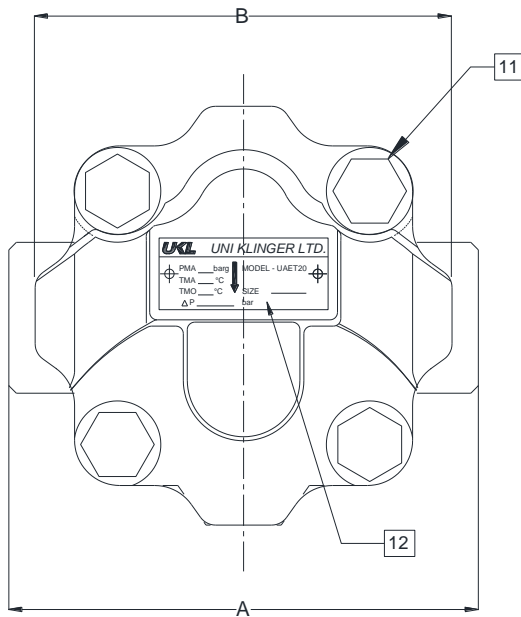

No.	PART NAME	MATERIAL	MATERIAL CODE	MATERIAL	MATERIAL CODE
1	Body	Cast Steel	ASTM A 216 Gr WCB	Cast Iron	IS 210 FG 260
2	Cover	Cast Steel	ASTM A 216 Gr WCB	Cast Iron	IS 210 FG 260
3	Pivot Pin	Stainless Steel	AISI 304	SS	AISI 304
4	Valve Seat	Stainless Steel	AISI 304	SS	AISI 304
5	Pivot Bracket	Stainless Steel	AISI 304	SS	AISI 304
6	Float Halves	Stainless Steel	AISI 304	SS	AISI 304
7	Lever	Stainless Steel	AISI 304	SS	AISI 304
8	Steel Ball	Stainless Steel	SS 440C	SS	SS 440 C
9	Cover Gasket	CAF	CAF	CAF	CAF
10	Valve Seat Gasket	Stainless Steel	AISI 304	SS	AISI 304
11	Cover Bolt (M10)	Carbon Steel	Gr. 8.8	Carbon Steel	Gr. 8.8
12	Name Plate	Stainless Steel	AISI 304	SS	AISI 304
13	Strainer	Stainless Steel	AISI 304	SS	AISI 304

Screwed / Socket Weld End Connections								
Size	Diff Pressure	A	B	C	D	E	F	Weight (kg)
15 NB	4.5/10/14 bar	128	111	68	179	30	110	
20 NB		128	111	68	179	30	110	
25 NB		153	111	75	202	30	130	

UKL-IM-UAET-R00-MAY 2017



TROUBLESHOOTING

- **Trap is leaking Liquid**
- The most likely reason for this is possible deposition of dirt on the valve seating area.
- Please ensure that the strainer screen is removed and cleaned properly. It is necessary to inspect the seat and spindle of any dirt deposition. If this is noticed, clean the surfaces and refit.
-
- **Trap is not Eliminating Air.**
- Make sure that the float has not been exposed to water hammer conditions. Float will get punctured and will soon get filled with water, losing its buoyancy and float does not rise on water level causing the trap to leak. Then replace the float with spare.
- These traps are most sensitive to differential pressure across the trap. If this differential pressure reduces or is nullified by high back pressure on the trap, the trap will not be able to release Air..
- Please ensure that the required differential pressure is available across the trap.
- If the problem persists, contact UKL.

4. Storage:

- UNI KLINGER UAET and the respective spares should be stored only in enclosed dry rooms in a non-aggressive atmosphere. Fully assembled Air Eliminator Traps must be stored as supplied by UNI KLINGER. Spare parts must be handled with care and should be stored in their original packing.
- It is recommended to take protective measures if parts are stored in dusty conditions.
- The ambient temperature in store room must be between -20 Deg. C and +50 Deg. C.
- Sudden change in temperatures must be avoided.
- Any damage due to inappropriate storage shall release UNI KLINGER of any obligations derived from warranty, guarantee, and product liability.



Other Products : Cast / Forged Steel Piston Valves, Bellow seal valves, High Pressure valves (Gate/Globe), Strainers – “Y” Type, ITVS Steam Traps (Thermodynamic, Thermostatic, Ball Float Traps and IBT), Pressure Reducing Station, Condensate Recovery Products. Level Gauges (Reflex, Transparent, Bicolor), Sight Glass, Hot Water Generation System, Safety and Relief Valves.
FSD Products : Compressed Asbestos / Non Asbestos Fiber Sheetting / Cut Gaskets, Spiral Wound Gaskets.

In view of technical progress design and dimensions are subjected to change without notice.



UNI KLINGER LIMITED

A joint venture of the Neterwala group of companies and KLINGER AG. Switzerland.

Central Sales Office & Pune Branch : SC1, 5th Fl., Kohinoor Est. Mumbai-Pune Highway, Kadaki, Pune-411 003. Tel.: +91-20-4102 3000 Fax.: (020) 4102 3001
e-mail : salesco@uniklinger.com, salespune@uniklinger.com, Website : www.uniklinger.com

Factory : C-37, M.I.D.C., Ahmednagar – 414 111, Maharashtra, Tel. : 0241 – 2777223 / 2777512 Fax : 0241 – 2777294, E-mail : fdworks@uniklinger.com

Branch Offices :

Baroda : 102, 1st Floor, Otel Towers-II R.C. Dutt Road, Baroda-390 005, Tel.: 91-0265-2312343 / 2340660, Fax.: 91-265-2341419. E-mail : salesbar@uniklinger.com
Chennai : East Coast Centre, 5th Floor, 553, Mount road, Teyanampet, Chennai - 600 018, Tel.: 91 - 44 - 24345707. Fax.: 91 - 44 - 24343960. E-mail : saleschen@uniklinger.com
Kolkata : 9, Chittrakoot, 8th Floor, 230 A, AJC Bose road, Kolkatta-700 020, Tel.: 91-33-22872510, Fax.: 91-33-22876494. E-mail : salescal@uniklinger.com
Mumbai : 22, 2nd Flr, Shreeji Arcade CHS, Almeda road, Thane-400 602, Tel.: 91-22-25421140 / 91-22-25440461, Fax.: 91-22-25440463. E-mail : salesmum@uniklinger.com
Delhi : 321, Ansal Chamber-II, 6, Bhikaji Cama Place, New Delhi-110 066, Tel.: 91-11-41658767 / 91-11-26193847, Fax.: 91-11-41658768. E-mail : salesdel@uniklinger.com