

## UKL AUTOMATIC PUMPING TRAP:-

UKL Automatic Pumping Trap is a low maintenance, non-electric solution to move condensate or other liquids from low points or low pressures or vacuum spaces to an area of higher elevation or pressure. Condensate can be returned at temperatures well above 93 Deg C limit of conventional pumps without the headaches of leaking seals or cavitation problems.

The UKL Automatic Pumping Trap operates on pressure difference across the trap.

The condensate from a process equipment (Dryer/ PHE), flows into main body. As the condensate level in the pump body rises the UFT controller float attached to outlet port also rises up and condensate flows out just as in Ball Float Traps. But when the UFT controller gets stall, the condensate level in the main body continues to rise which causes the float attached to central fork also rise. At a predetermined float position, a spring aided mechanism snaps open the motive pressure inlet valve so that motive fluid flows in the main body of UAPT. This motive fluid drive the condensate towards outlet. When the condensate is pumped the level inside the main body falls causing float attached to central fork to descend towards lower position. At this point the spring mechanism again snaps back to open exhaust valve and close the motive fluid inlet valve. The exhaust valve open to drive the expanded motive fluid by incoming condensate, to be driven out of UAPT.

## Features of UAPT:-

Economical non-electrical operation. Uses inexpensive steam, air or inert gas.

Low-maintenance operation. No leaking seals, impeller or motor problems mean lower maintenance. No NPSH issues which are very common in conventional pumps.

Use of inlet and outlet check valves for the proper operation of the pumping trap.

Space-saving size. Low-profile body fits in tight spaces while allowing minimal fill head.

Inlet and outlet check valves are comprising of Stainless steel material owing to corrosive nature of the condensate

High efficiency. A closed loop means no motive or flash steam is lost. All valuable heat are captured and returned to the system only

Motive steam line is provided at the head of the Automatic pumping trap

Corrosion resistance. All the internal components are either stainless steel or inconel for corrosion resistance and long service life



## MATERIAL OF CONSTRUCTION:

Body: - Carbon Steel  
Internals - Inconel & Stainless Steel

## SIZES AVAILABLE:-

Inlet 25 NB and Outlet 25 NB  
Inlet 40 NB and Outlet 25 NB

## AVAILABLE MODEL:-

UAPT-4.5  
UAPT-10  
UAPT-14

## END CONNECTIONS:

Flanged - #150/#300 as per ASME B 16.5

## OPERATING CONDITIONS:-

Max. Allowable Pressure :- 14 kg/cm<sup>2</sup>  
Max. Allowable Temp :- 180°C

## OPTIONAL :-

UAPT Assembly with Flash Vessel and  
Sight Glass as per customer requirement.

# Automatic Pumping Trap UAPT

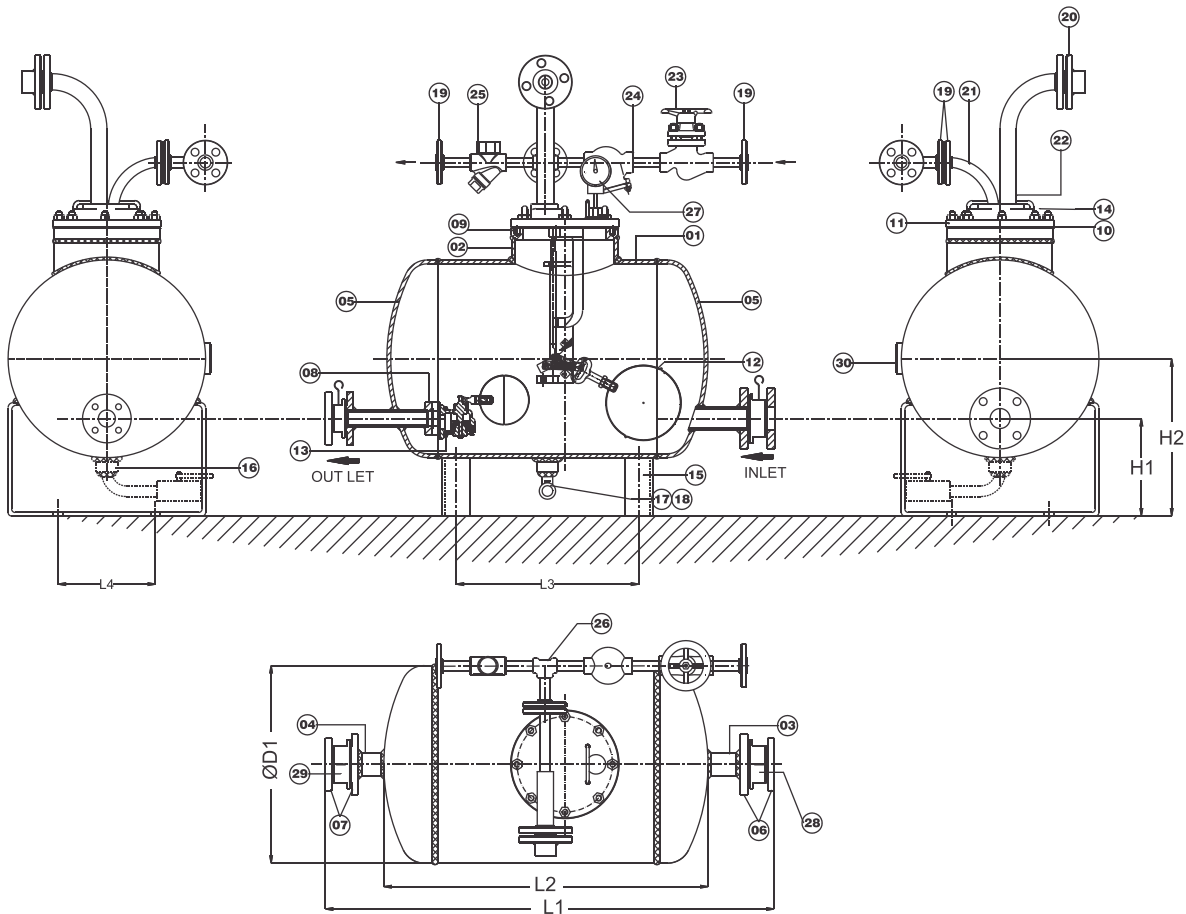

## DIMENSIONS (mm)

ØD1	L1	L2	L3	L4	H1	H2
406	830	660	300	200	200	325

## BILL OF MATERIAL

Sr.	Description	MOC
01	Seamless Pipe 16" Sch. 20	ASTM A106 Gr.B
02	Seamless Pipe 8" Sch. 40	ASTM A106 Gr.B
03	Seamless Pipe 1 1/2" Sch. 40	ASTM A106 Gr.B
04	Seamless Pipe 1" Sch. 40	ASTM A106 Gr.B
05	Dish End 16" (Min W.T. 8.0)	Carbon Steel
06	SWRF 1 1/2" #150	ASTM A105
07	SWRF 1" #150	ASTM A105
08	Pipe Bracket	Carbon Steel
09	Cover Ring	Carbon Steel
10	Cover Gasket	CAF
11	Cover	Carbon Steel
12	APT Internal Assembly	As per UKL Std.
13	UFT Controller 50 NB	As per UKL Std.
14	Stud - Nut	Carbon Steel
15	Support Stand - Flat 50 x 5	Carbon Steel
16	Half Coupling - 1/2" BSP	Carbon Steel

Sr.	Description	MOC
17	Bend - 1/2" BSP	Carbon Steel
18	Ball Valve - 1/2" BSP	Carbon Steel
19	SWRF 1/2" #150	ASTM A105
20	SWRF 1 #150	ASTM A105
21	Long Bend 1/2" Sch. 40 / 80	ASTM A106 Gr.B
22	Seamless Pipe 1" Sch. 40	ASTM A106 Gr.B
23	Inlet Piston Valve - 15 NB	Carbon Steel
24	Y Type Strainer - 15 NB	Carbon Steel
25	UTD-55 Trap - 15 NB - BSP	Carbon Steel
26	Tee 1/2" BSP	Carbon Steel
27	Pressure Gauge	SS - Dial 63 mm
28	NRV at Inlet	ASTM A351 Gr. CF8
29	NRV at Outlet	ASTM A351 Gr. CF8
30	Name Plate	SS
31	UTST- 15 NB - BSP	Carbon Steel

# Automatic Pumping Trap UAPT

The UAPT size to be selected from the table given below-

Motive Pr.	Back Pressure	Discharge Capacity (in LPH)	
		25 NB	40 NB
kg/cm <sup>2</sup>	kg/cm <sup>2</sup>		
1	0.5	1612	2208
	1	1565	2144
	1.5	1474	2078
2	0.5	1865	2592
	1	1745	2530
	1.5	1590	2273
3	0.5	1982	2794
	1	1823	2570
	1.5	1737	2414
5	0.5	2132	3027
	1	2013	2777
	1.5	1929	2662

## Sizing and Selection of UKL APT

If you are required to select a suitable UKL Automatic Pumping Trap, proceed as follows-

Condensate to be handled 2000 LPH  
Motive steam pressure Available 3 kg/cm<sup>2</sup>

Delivery Head 6 m  
Frictional Losses in horizontal Distance 4 m

**Pressure in line where the condensate is being returned must also be considered.**

Back Pressure against which Pump has to operated 1 kg/cm<sup>2</sup>

Now look at table given on Left Hand Side  
Select 3 kg/cm<sup>2</sup> motive pressure line  
Pick up 1 kg/cm<sup>2</sup> Back Pressure  
Select UAPT Unit size that gives flow rate in excess of required.  
In above example 40 NB size UAPT is selected.

Diff. Pressure	Discharge Capacity (LPH)	
	25 NB	40 NB
kg/cm <sup>2</sup>		
0.2	4555	5780
0.5	7000	8610
1	10120	12042
1.5	12690	15980
3.5	12690	17890
5	12690	21468
7	12690	25120
10	12690	29390
14	12690	34380

## Product Range

### UTD-55 | UTD-62 | UTD-120

Thermodynamic steam trap

### UTST | UCT-10

Thermostatic steam trap & Sanitary steam trap

### UFT-15 to 100 | UCA

Ball Float Trap for Steam and air application

### UG 25/45 | UP64Ti | UP215Ti

Bi-metallic Steam Trap

### UITVS

Compact Trap Valve Station

### UIBT-28US

Inverted bucket Steam Trap in complete stainless steel construction

### UIBT 1701 to 7004

Inverted bucket steam trap in cast/forged steel construction

### UDCV

Wafer type disc check valve / NRV

### UMS

Moisture separator for Steam & Air

### UAV

Thermostatic air vent for steam with air bottle for proper venting

### UAE

Air eliminator for liquid application

### UBSV

Bellow seal gate/globe valve

### UPHV

High pressure (#1500/#2500) gate/globe valve

### USTR

Y & T type strainers in cast carbon steel and stainless steel

### USG

Double window sight glass

### USI

Steam injector for boiler feed water tank

### UFV

Condensate flash vessel

### UPPPU

Condensate pressure powered pump unit

### UDH

Atmospheric de-aerator head for boiler feedwater tank

### UAPT

Automatic pumping trap – Combination of a conventional trap & pump for proper condensate discharge for varied applications

### UCCDS

Online (24x7) condensate contamination detection system

### UBBHRS

Boiler blowdown heat recovery system

### UHWGS

Instant Hot water generator system

### UPRS / UPRDS

Pressure reducing system & de-superheating system

### UCCM / USDM

Steam / Condensate manifolds

### Other Products :



Cast / Forged Steel Piston Valves, Bellow seal valves, High Pressure valves (Gate/Globe), Strainers – “Y” Type, ITVS Steam Traps (Thermodynamic, Thermostatic, Ball Float Traps and IBT), Pressure Reducing Station, Condensate Recovery Products, Level Gauges (Reflex, Transparent, Bicolor), Sight Glass, Hot Water Generation System, Safety and Relief Valves.

**FSD Products :** Compressed Asbestos / Non Asbestos Fiber Sheetting / Cut Gaskets, Spiral Wound Gaskets / Gland Packing



## UNI KLINGER LIMITED

In view of technical progress designs and dimensions are subject to change without notice.

A joint venture of the Neterwala group of companies and KLINGER AG, Switzerland.

Central Sales Office & Pune Branch : SC1, 5th Fl., Kohinoor Est. Mumbai-Pune Highway, Khadki, Pune-411 003.

Tel.: +91-20-4102 3000 Fax.: (020) 4102 3001

e-mail : salescso@uniklinger.com, salespune@uniklinger.com, Website : www.uniklinger.com

Factory :

C-37, M.I.D.C., Ahmednagar – 414 111, Maharashtra, Tel. : 0241 – 2777223 / 2777512

Fax : 0241 – 2777294, E-mail : fcdworks@uniklinger.com

### Branch Offices :

**Baroda** : 102, Ofitel Towers-II 1st Floor, R.C. Dutt Rd, Baroda-390 005, **Tel.:** 91-0265-2312343 / 2340660, **Fax.:** 91-265-2341419. **E-mail :** salesbar@uniklinger.com

**Chennai** : East Coast Centre, 5th Floor, 553, Mount Rd, Teyanampet, Chennai - 600 018, **Tel.:** 91 - 44 - 24345707. **Fax.:** 91 - 44 - 24343960. **E-mail :** saleschen@uniklinger.com

**Kolkata** : 9, Chitrakoot, 8th Floor, 230 A, AJC Bose Rd, Kolkatta-700 020, **Tel.:** 91-33-22872510, **Fax.:** 91-33-22876494. **E-mail :** salescal@uniklinger.com

**Mumbai** : 714, Ecstasy, City of Joy Complex, J.S.D. Rd, Mulund (W) Mumbai - 400080, **Tel.:** 91-22-25440463, **Fax.:** 91-22-25440463. **E-mail :** salesmum@uniklinger.com

**New Delhi** : 1003, 10th Flr., Indra Prakash Bldg. 21, Barakhamba Rd, Connaught Place New Delhi-110001, **Tel.:** 91-11-41658767, **Fax.:** 91-11-41658768. **E-mail :** salesdel@uniklinger.com

